

• General Description

It combines advanced trench MOSFET technology with a low resistance package to provide extremely low $R_{DS(ON)}$.

• Features

- Advance high cell density Trench technology
- Low $R_{DS(ON)}$ to minimize conductive loss
- Low Gate Charge for fast switching
- Low Thermal resistance

• Application

- SMPS 2nd Synchronous Rectifier
- BLDC Motor driver

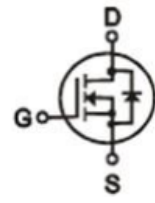
• Product Summary

$V_{DS} = 100V$

$R_{DS(ON)} = 10m\Omega$

$I_D = 46A$

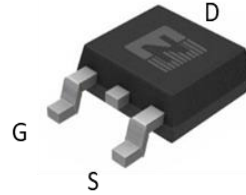

TO-252

• Ordering Information:

Part NO.	ZMS100N10D
Marking	ZMS100N10
Packing Information	REEL TAPE
Basic ordering unit (pcs)	2500

• Absolute Maximum Ratings ($T_C = 25^\circ C$)

Parameter	Symbol	Rating	Unit
Drain-Source Voltage	V_{DS}	100	V
Gate-Source Voltage	V_{GS}	± 20	V
Continuous Drain Current ^②	$I_{D@TC=25^\circ C}$	46	A
	$I_{D@TC=75^\circ C}$	35	A
	$I_{D@TC=100^\circ C}$	29	A
Pulsed Drain Current ^①	I_{DM}	138	A
Total Power Dissipation ^②	$P_D@TC=25^\circ C$	60	W
Total Power Dissipation	$P_D@TA=25^\circ C$	2.0	W
Operating Junction Temperature	T_J	-55 to 150	$^\circ C$
Storage Temperature	T_{STG}	-55 to 150	$^\circ C$
Single Pulse Avalanche Energy @ $L=0.1mH$	E_{AS}	60	mJ

**•Thermal resistance**

Parameter	Symbol	Min.	Typ.	Max.	Unit
Thermal resistance, junction - case ^②	R _{thJC}	-	-	2.2	° C/W
Thermal resistance, junction - ambient	R _{thJA}	-	-	64	° C/W
Soldering temperature	T _{sold}	-	-	260	° C

•Electronic Characteristics

Parameter	Symbol	Condition	Min.	Typ	Max.	Unit
Drain-Source Breakdown Voltage	BV _{DSS}	V _{GS} =0V, I _D =250uA	100			V
Gate Threshold Voltage	V _{GS(TH)}	V _{GS} =V _{DS} , I _D =250uA	1.3		2.5	V
Drain-Source Leakage Current	I _{DSS}	V _{DS} =100V, V _{GS} =0V			1.0	uA
Gate- Source Leakage Current	I _{GSS}	V _{GS} =±20V, V _{DS} =0V			±100	nA
Static Drain-source On Resistance	R _{DS(ON)}	V _{GS} =10V, I _D =20A		10	12.8	mΩ
	R _{DS(ON)}	V _{GS} =4.5V, I _D =16A		12.5	15	mΩ
Forward Transconductance	g _{FS}	V _{DS} =25V, I _D =15A		15		s
Diode Forward Voltage	V _{FSD}	I _S =20A			1.28	V

•Electronic Characteristics

Parameter	Symbol	Condition	Min.	Typ	Max.	Unit
Input capacitance	C _{iss}	V _{GS} =0V, V _{DS} =25V f = 1MHz	-	1400	-	pF
Output capacitance	C _{oss}		-	630	-	
Reverse transfer capacitance	C _{rss}		-	33	-	

Gate Charge characteristics(T_a= 25°C)

Parameter	Symbol	Condition	Min.	Typ	Max.	Unit
Total gate charge	Q _g	V _{DD} =30V	-	20	-	nC
Gate - Source charge	Q _{gs}	I _D = 8A	-	3.6	-	
Gate - Drain charge	Q _{gd}	V _{GS} = 10V	-	2.8	-	

Note: ① Pulse Test : Pulse width ≤ 300μs, Duty cycle ≤ 2% ;

② Device mounted on FR-4 substrate PC board, 2oz copper, with thermal bias to bottom layer 1inch square copper plate;

Fig.1 Gate-Charge Characteristics

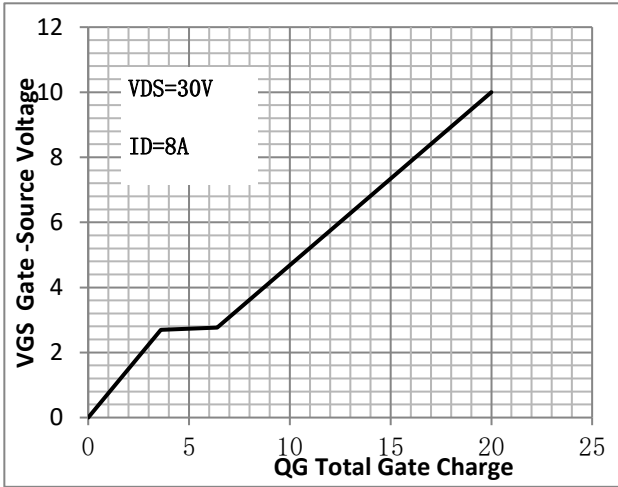

Fig.2 Capacitance Characteristics

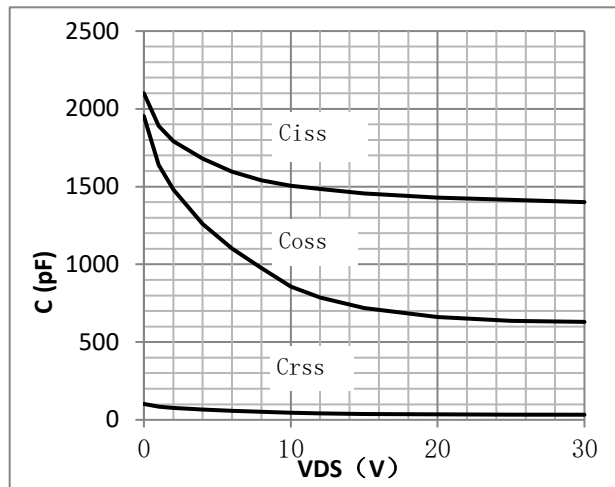

Fig.3 Power Dissipation

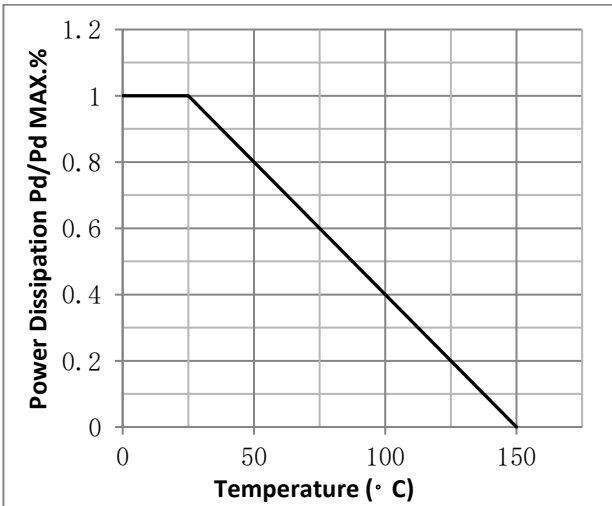

Fig.4 Typical output Characteristics

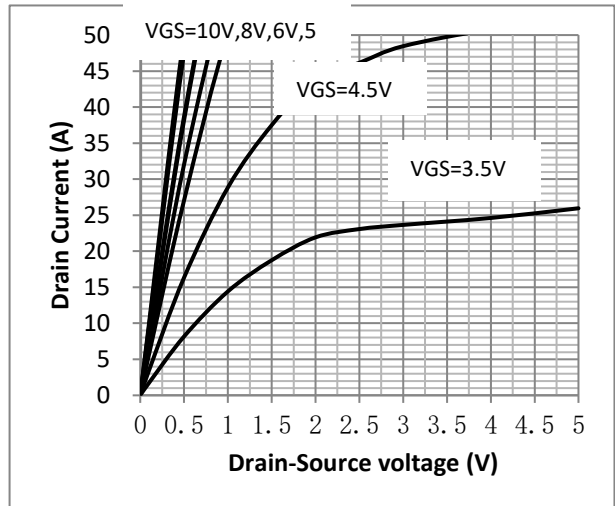

Fig.5 Threshold Voltage V.S Junction Temperature

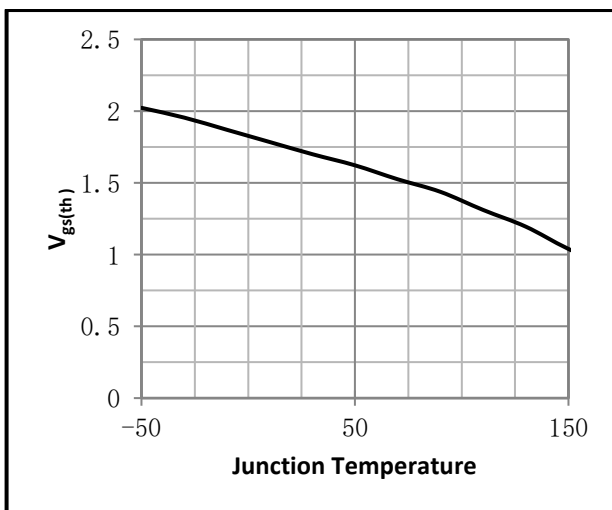

Fig.6 Resistance V.S Drain Current

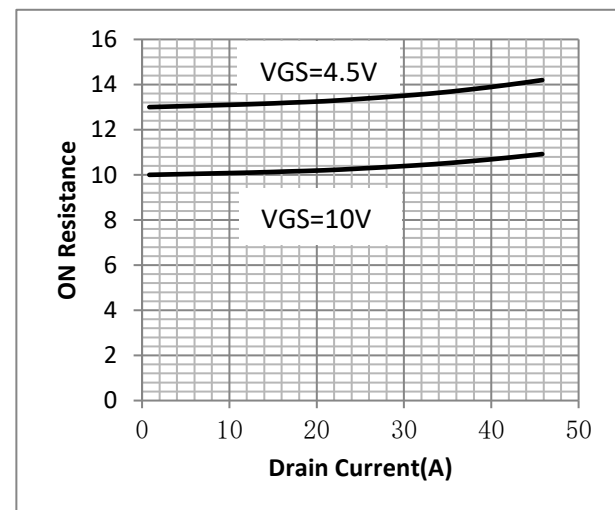

Fig.7 On-Resistance VS Gate Source Voltage

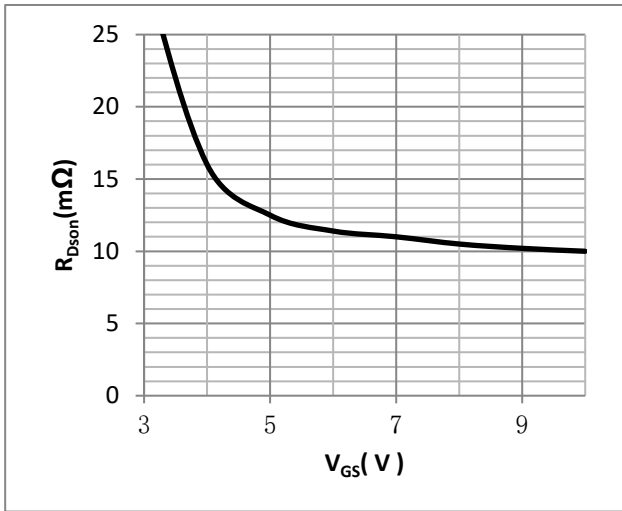

Fig.8 On-Resistance V.S Junction Temperature

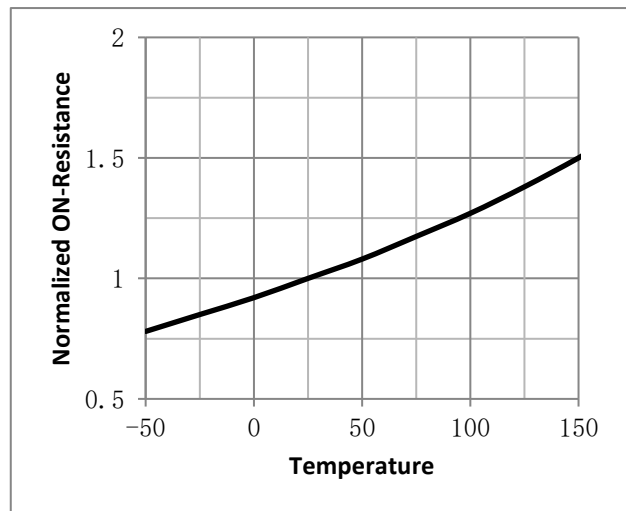

Fig.9 SOA Maximum Safe Operating Area

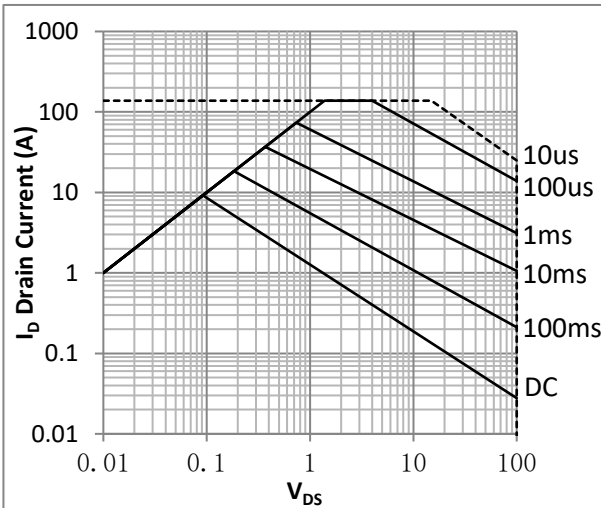

Fig.10 I_D -Junction Temperature

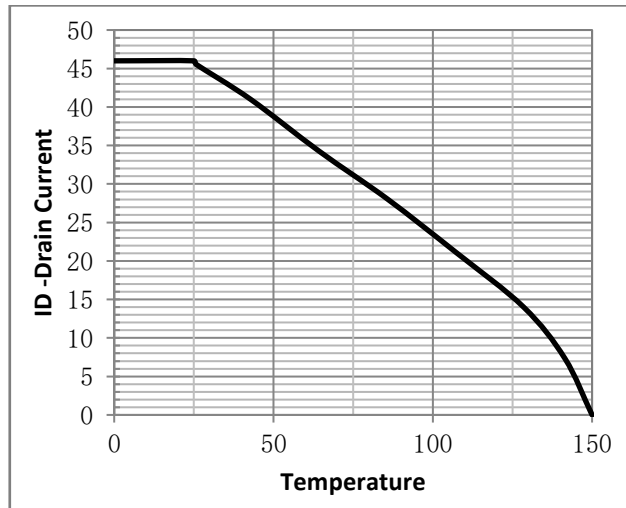

Figure 11. Diode Forward Voltage vs. Current

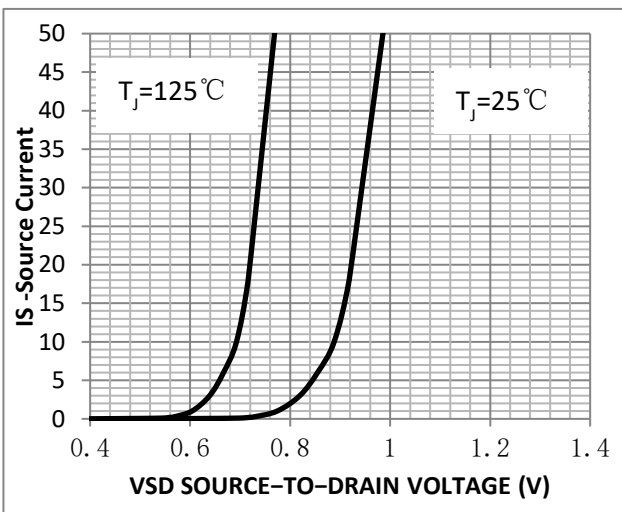

Figure 12. Transfer Characteristics

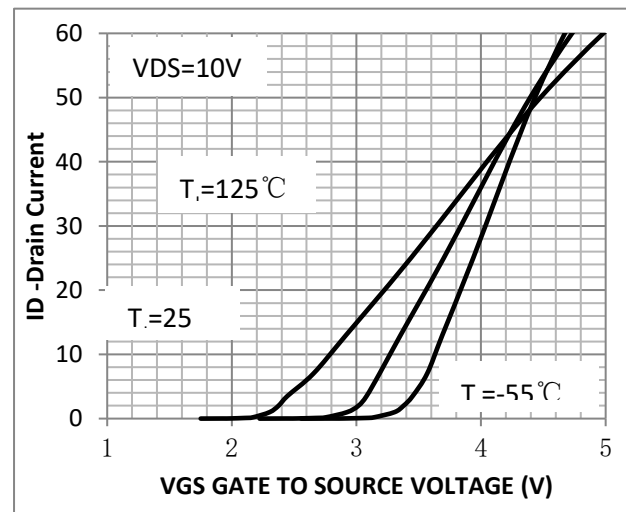

Fig.12 Gate Charge Measurement Circuit

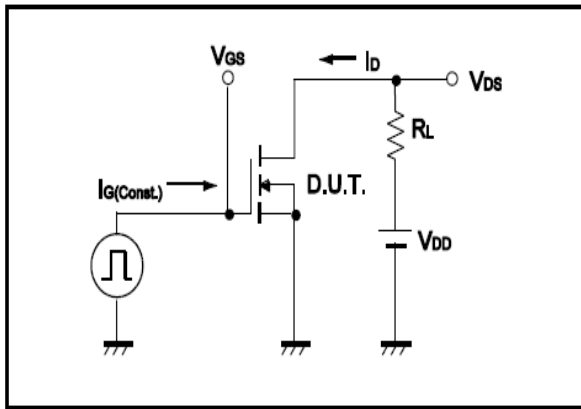

Fig.13 Gate Charge Waveform

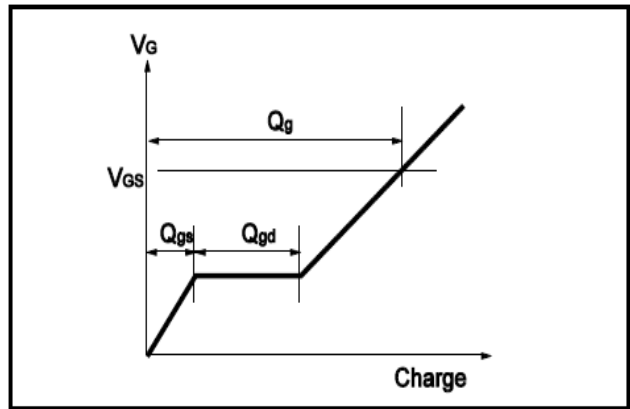

Fig.14 Switching Time Measurement Circuit

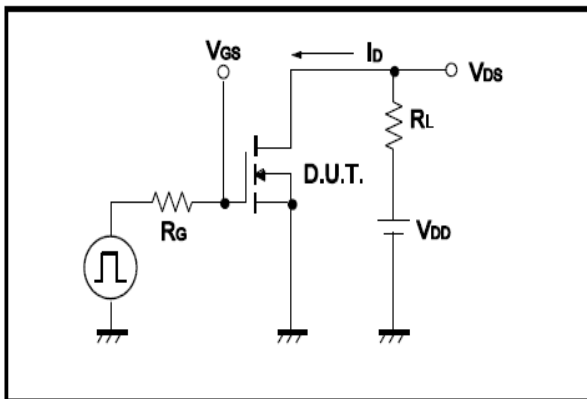

Fig.15 Switching Time Waveform

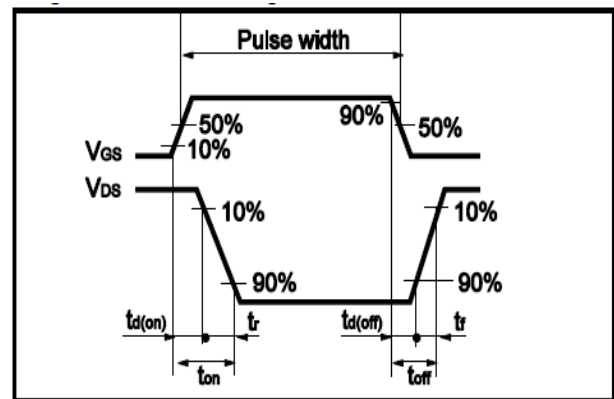

Fig.16 Avalanche Measurement Circuit

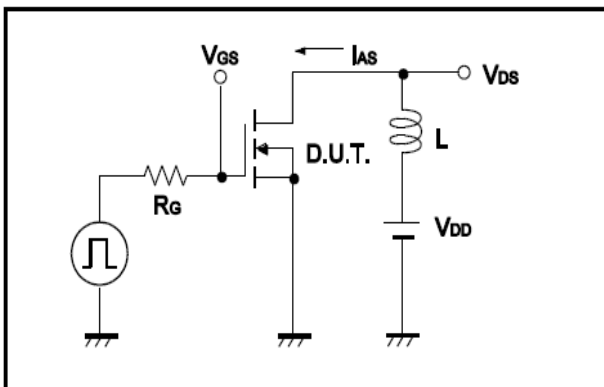
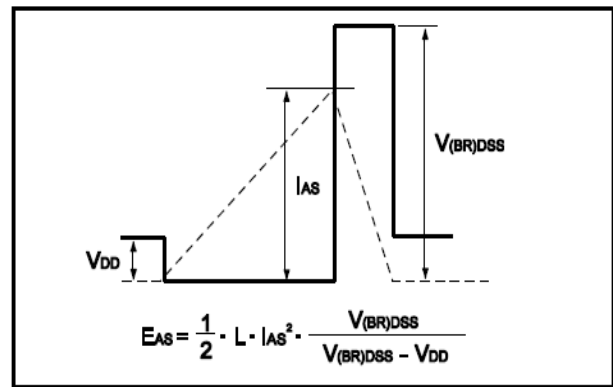

Fig.17 Avalanche Waveform





• Dimensions (TO-252)

Unit: mm

SYMBOL	min	max	SYMBOL	min	max
A	2.10	2.50	B	0.85	1.25
b	0.50	0.80	b1	0.50	0.90
b2	0.45	0.70	C	0.45	0.70
D	6.30	6.75	D1	5.10	5.50
E	5.30	6.30	e1	2.25	2.35
L1	9.20	10.60	e2	4.45	4.75
L2	0.90	1.75	L3	0.60	1.10
K	0.00	0.23			

